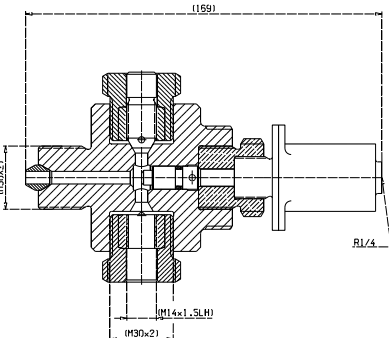
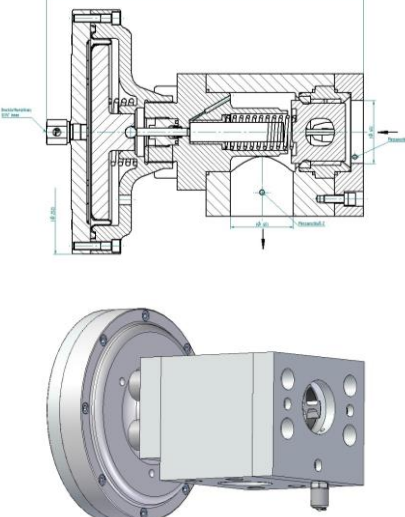

DISCHARGE FITTINGS

NON-RETURN VALVE (RV)

08.G.12 – 11/19

The non-return valve (RV) acts as a pneumatically actuated shut off element, opening when the min. operating pressure which can be variably defined has been reached and remains open only if a min. volume in the flow direction is maintained. The non-return valve shuts off the backflow against the flow direction.

	Non-return valves	Code no.
	<p>Non-return valve with pneumatic controlled cylinder</p> <p>Operating pressure max.: 2500 bar Opening pressure: 0 - 10 bar Air pressure max.: 8 bar Nominal diameter: i/d 6 mm</p> <p><u>HP connection:</u> Inlet P: M 30 x 2 external and Outlet A1: M 30 x 2 internal Outlet A2: M 30 x 2 internal, locked</p>	<p>00.05876.0050</p>
	<p>Non-return valve with pneumatic controlled membrane cylinder</p> <p>Operating pressure max.: 300 bar Flow rate max.: 750 l/min</p> <p><u>Opening pressures:</u> approx. 0.6 bar (without air pressure) approx. 8 bar (at 1 bar air pressure) approx. 50 bar (at 6 bar air pressure) (2 measuring connectors)</p> <p><u>HP connection:</u> Inlet P: SAE 2 1/2"; 6000 lbs. Outlet A: SAE 2 1/2"; 6000 lbs.</p>	<p>00.05876.0064</p>



Use Silver Goop (code no. 04.00982.0010) as lubricant for stainless steel and alloys!
 Not applicable for aluminum and magnesium!



The non-return valve (RV) and the throttle check valve (DRRV) must not be used for high pressure operations with hand held spraying devices. The unrestricted pressure release in the hose line via the bypass valve must be ensured to reduce to a minimum the duration of potential hazard of high pressure fluid emerging from the consumer

HAMMELMANN®