

SEMI-AUTOMATIC UHP WATER BLASTING VEHICLE FOR SHIP HULL AND TANK SURFACE PREPARATION

The *DOCKMATE*® is a completely **dust free**, eco-friendly alternative to dry open capable of preparing hull surfaces to the most exacting standards applicable to

Using pressures varying between 2500 and 3000 bar up to 250 sq. metres per The 4 wheel drive is powered by hydraulic motors with built in limited slip differ

Technical data *DOCKMATE*®:

Operating pressure:	max. 3000 bar	
Working heights telescopic jib:	12 to 14 m* up to 22 m up to 27 m up to 32 m	
Dimensions <u>without</u> telescopic mast: (L x W x H)	4,73 x 2,55 x 2,9 m	
Dimensions <u>with</u> telescopic mast: (L x W x H)	13,0 x 2,55 x 3,1 m	22 m
	15,0 x 2,55 x 3,1 m	27 m
	17,0 x 2,55 x 3,1 m	32 m
Weight:	16,0 t*	
	19,0 t	22 m
	21,0 t	27 m
	23,0 t	32 m

* without telescopic mast

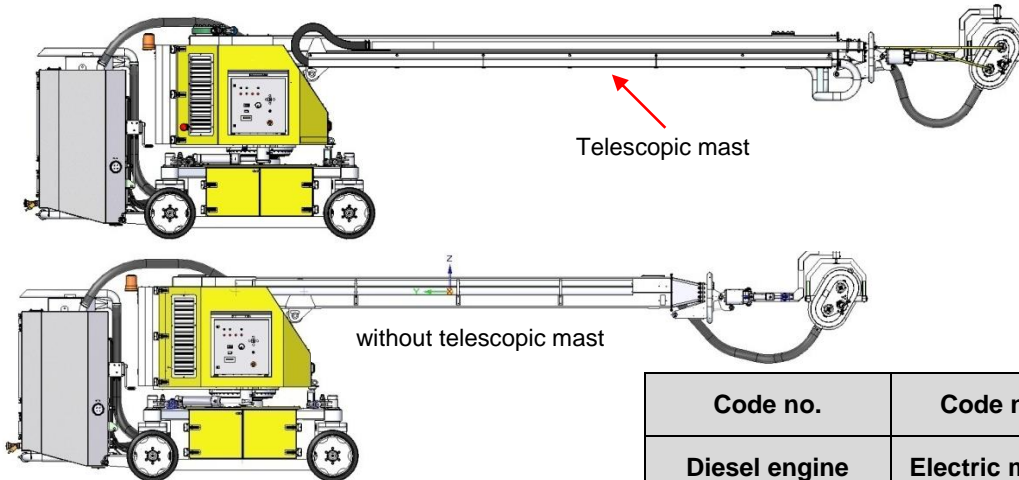
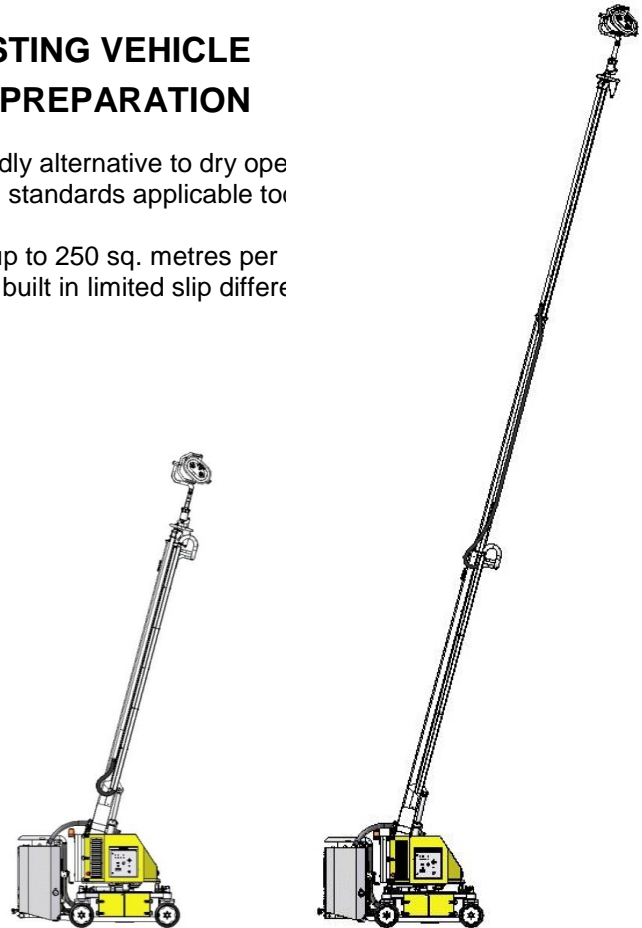

The *DOCKMATE*® is operated by portable remote control.

	Code no.	Code no.	Code no.	
Length of the telescopic jib	Diesel engine	Electric motor	Diesel engine	
	CAT C4.4 EU step IIIA Constant speed (for europe not for USA/Canada)		CAT C4.4 EU step IIIA - EPA Tier 3 for countries of the emission step IIIA	
	12 to 14 m*	00.00748.0007	---	---
	up to 22 m	00.00748.0008	00.00748.0018	00.00748.0020
	up to 27 m	00.00748.0013	00.00748.0017	00.00748.0019
up to 32 m	00.00748.0014	00.00748.0015	00.00748.0016	

SEMI-AUTOMATIC UHP WATER BLASTING VEHICLE FOR SHIP HULL AND TANK SURFACE PREPARATION

AQUABLAST®:

A working arm functioning as an equipment carrier is installed at the tip of the telescoping jib.



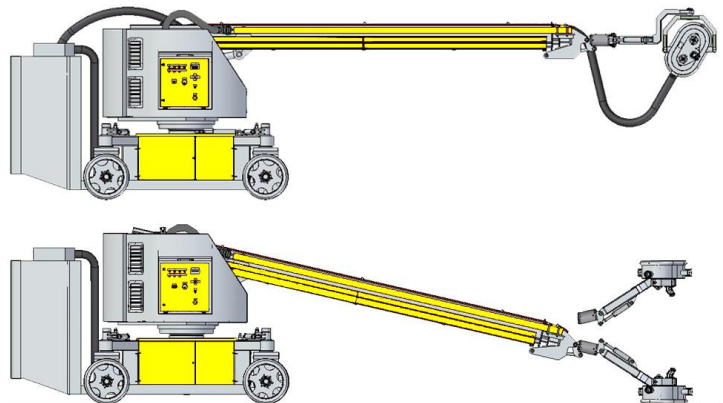

The blasting head is a HAMMELMANN AQUABLAST® with a choice of from one to three leakage free sealed high pressure rotary joints. It can be swivelled so that both horizontal and overhead surfaces can be cleaned.

All three versions are driven by a single hydraulic motor using a ribbed drive belt.



The blasting head seals directly onto the hull surface and is connected to the vacuum unit via a hose/pipe combination.



			
Spot blasting			
Working width (optional)	Working width (optional)	Working width (optional)	Working width (optional)
278 mm (Spot) 374 mm (Surface)	374 mm	520 mm	1000 mm
Flow rate	Flow rate	Flow rate	Flow rate
28 - 65 l/min	28 - 50 l/min	40 - 65 l/min	75 - 100 l/min
Operating pressure			
2800 - 3000 bar			
Weight	Weight	Weight	Weight
141 kg	158 kg	178 kg	275 kg
Code no.	Code no.	Code no.	Code no.
00.00078.0022	00.00078.0047	00.00078.0053	00.00078.0055

SEMI-AUTOMATIC UHP WATER BLASTING VEHICLE FOR SHIP HULL AND TANK SURFACE PREPARATION



All components are easy accessible and service friendly installed.

Filtration

