

AQUABLAST® FR 1500

- Spray bar driven by reaction force of the water jets.
- Wear resistant rotary action with labyrinth seal.
- Optional pressure ON/OFF control. Mechanical bypass valve or electric in 4-pole system signal to pump. Special controls available upon request.
- ON/OFF control by twin trigger action.
- Four wheel carriage.
- Choice of version with or without protection for spray bar.



TYPICAL APPLICATIONS

AQUABLAST® WITHOUT PROTECTION

- Grid cleaning.
- Paint removal on steel plates.

AQUABLAST® WITH PROTECTION

- Floor cleaning.
- Roughening concrete surfaces.
- Removing road markings from concrete.

TECHNICAL DATA

Operating pressure max.:	1500 bar
Working width:	400 mm
Flow rate max.:	150 l/min
Pressure loss at 50 l/min:	5 bar
Pump power max.:	200 kW
Speed of rotation:	1000 min ⁻¹
Length:	approx. 1350 mm
Height:	approx. 940 mm
Unit width:	approx. 462 mm
Connection thread:	M 24 x 1.5 DKO-S



The AQUABLAST® may only be driven with four nozzles. Nozzle inserts design "A", "B" or "M"

Description	Pressure ON / OFF	Weight [kg]	Code no.
Grid cleaning (without protection)	mechanical	90.0	09.00661.0159
	electrical	78.5	09.00661.0150
Concrete removal (with protection)	mechanical	---	---
	electrical	81.0	09.00661.0173

Description	Code no.
Extra weight, 33 kg	01.01390.0020

AQUABLAST® FR 1500

ACCESSORIES AND SPARES

13.D.5 - 07/2021

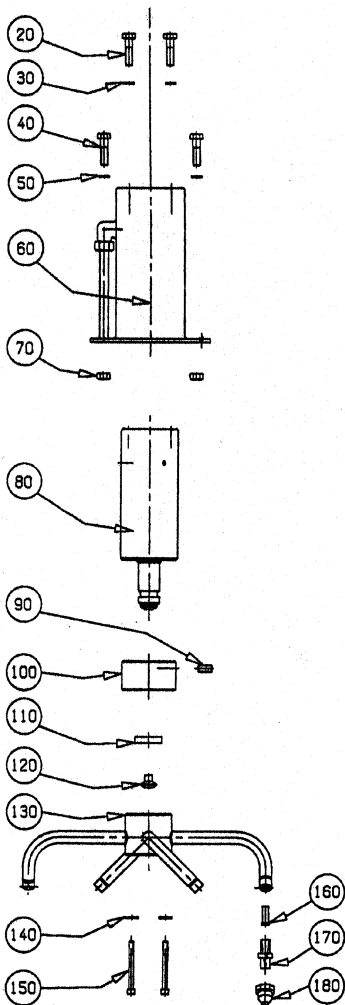
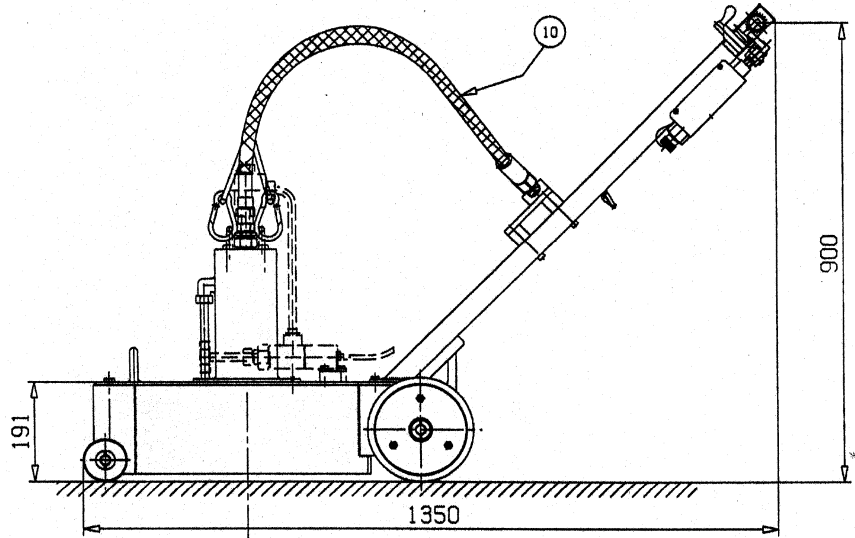

Item no.	Qty.	Descripton	Code no. / per single item
10	1	High pressure hose	04.04599.1262
	1	Hose arrester	04.04608.0038
	2	Karabiner hook	02.01360.0003
20	4	Screw	02.00825.0047
30	4	Spring washer	02.00384.0008
40	4	Screw	02.00671.0121
50	4	Spring washer	02.00380.0007
60	1	Sleeve	00.01750.0432
70	4	Nut	02.00309.0007
80	1	Rotary joint	00.00062.0130
90	1	Set screw	02.00888.0308
100	1	Flange	01.01055.0681
110	1	Split ring	01.03465.0510
120	1	Seal lense	01.00727.0044
130	1	Spray bar for grid cleaning	00.03567.1138
	1	Spray bar for concrete removal	00.03567.1178
140	4	Spring washer	02.00384.0006
150	4	Screw	02.00825.0020
160	4	Sleeve	00.01750.0426
170	4	Nozzle insert design "A", "B" or "M"	see chapter 12
180	4	Retaining nut	01.02833.0066

Spray bar complete, items 90 - 180 without nozzle inserts	00.03567.1139
---	---------------

