

SUCTION SIDE CONNECTION FITTINGS WITH FILTER - SPECIAL FILTER

11.D.8 – 09/18

Twin stainless steel back flushing filter Type EZF 1000 with ZEOLITE sand filter substrate permanently mounted in a steel container

- Container: 2438 x 2591 x 2931 mm (W x H x L)
- Container fork lift shoes: 320 x 90 x 940 mm (W x H x Centres)
- Container paint: RAL 5010 Gentian blue (standard)
- Connection: 3 x A Storz, couplings at container, outer wall, each filter
- Filter type: 2 x EZF-1000, complete with pipe work
- Operating over pressure: 1 to 6 bar
- Filter substrate: Leaf shaped Zeolite crystals max. 6 mm
- Filter support grit: Grit 2 to 3,15 mm
- Differential pressure indicators: 2 x gauges (standard model)

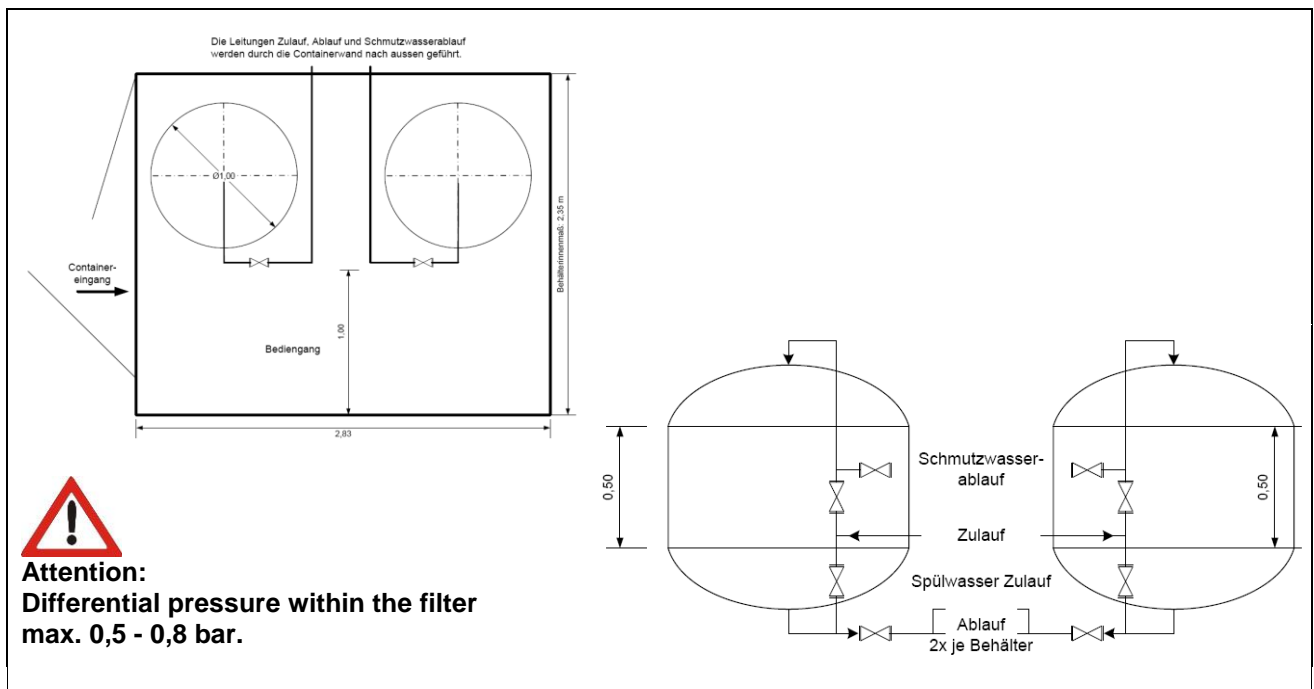

Filter type	Reservoir capacity [liter]	Filtration performance at 50 m/h [m³/h]	Connection inlet-outlet, flush connect. [i/d]	Support grit [kg]	Filter layer at 1 x filter [kg]	Press. vessel dia. [mm]	Total height [mm]	Code no.
EZF-1000	approx. 1180	78 (1300 l/min.)	100	150	425	1000	1650	04.01030.0028

Accessories for all filter types	Code no.
- Pallet for Transport / Secure footing of the filter	04.03135.0003
- Zuprafiltr filter filling for type EZF dirt filtering units (grain size 1 - 6 mm; 25 kg)	04.01033.0001
- Quartz support grit for type EZF dirt filtering units (grain size 2 - 3,15 mm; 50 kg)	04.01033.0002
- Differential pressure gauge 100 mm dia.; 0 - 2,5 bar for all manually operated EZF filters	upon request
- Automatic back flushing via electric differential pressure monitoring	upon request

HAMMELMANN®