

SUCTION SIDE CONNECTION FITTINGS WITH FILTER - SPECIAL FILTER -

Stainless steel back flushing filter Type IFB-Z with ZEOLITE sand filter substrate

- Connection: Storz coupling
- Operating over pressure: 1 to 10 bar
- Filter substrate: Leaf shaped zeolite crystals max. 6 mm
- Filter support grit: Grit 2 to 3,15 mm
- Differential pressure indicators: 2 x gauges 0 to 10 bar (standard model) with safety valve (10 bar)

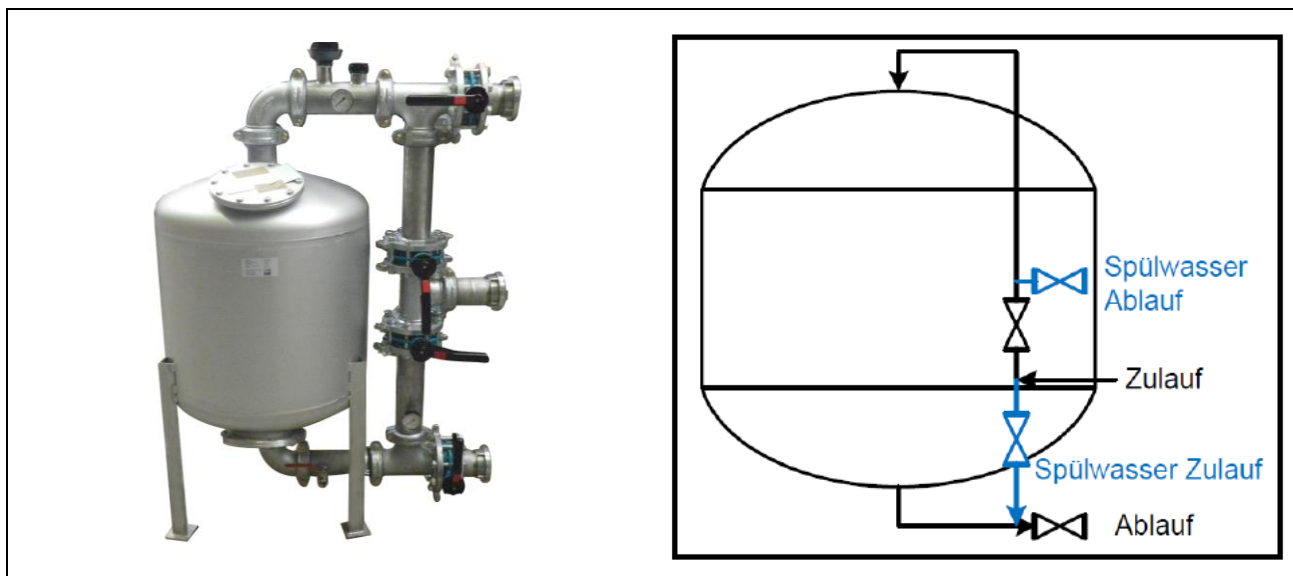

Filter type	Reservoir capacity [liter]	Filtration performance at 50 m/h [m ³ /h]	Connection inlet-outlet; flush connect.	Support grit [kg]	Filter layer [kg]	Press. vessel dia. [mm]	Total height [mm]	Code no.
IFB-Z-500	approx. 135	10 (165 l/min.)	i/d 65 / B75 coupling	25	105	500	1580	04.01030.0030
IFB-Z-650	approx. 240	16 (265 l/min.)	i/d 80 / B75 coupling	75	180	650	1600	04.01030.0029
IFB-Z-800	approx. 365	25 (415 l/min.)	i/d 100 / A110 coupling	100	270	800	1620	04.01030.0031
IFB-Z-1000	approx. 590	39 (650 l/min.)	i/d 100 / A110 coupling	150	405	1000	1650	04.01030.0032



Attention: Differential pressure within the filter max. 0,5 – 0,8 bar.